

Atlantis 60 Scorrevole

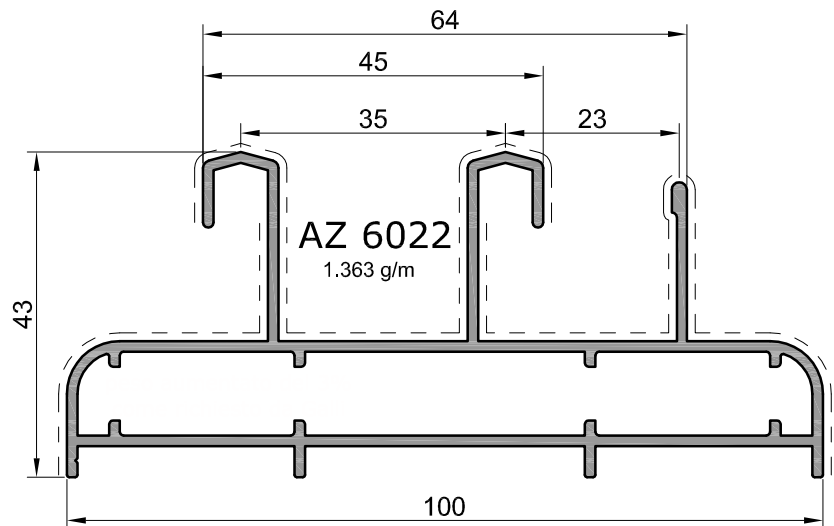

AZ 6009

807 g/m

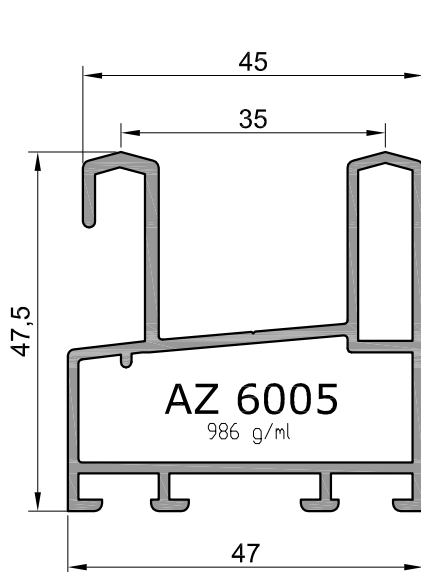
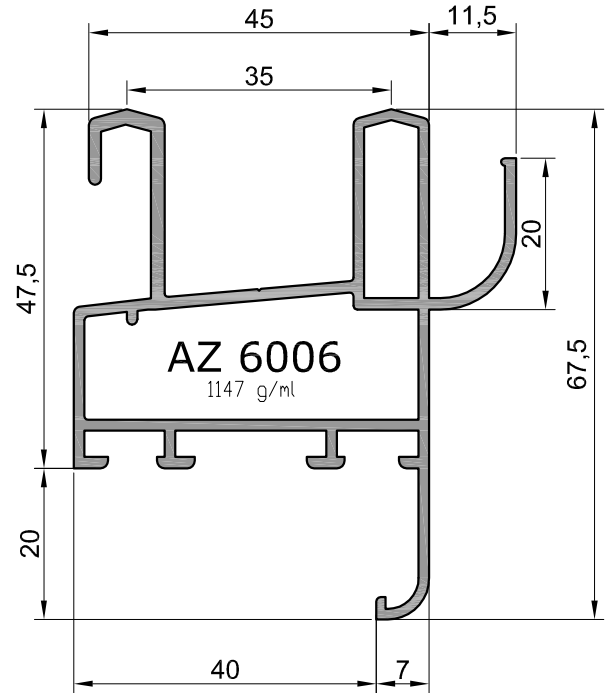
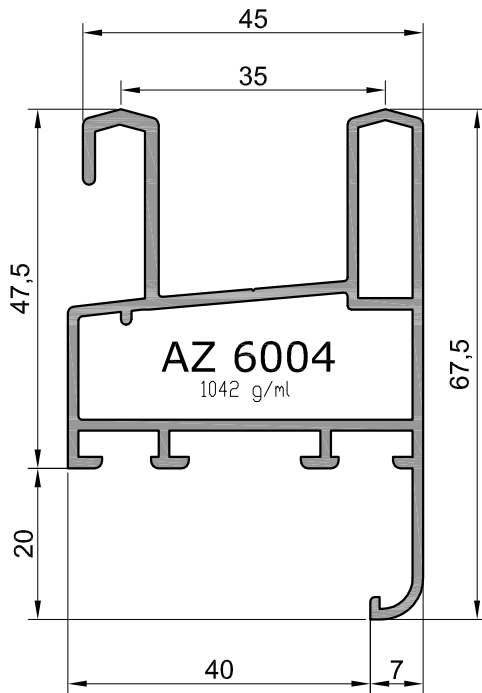
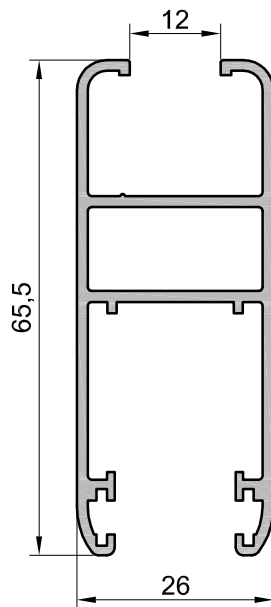

AZ 6008

775 g/m

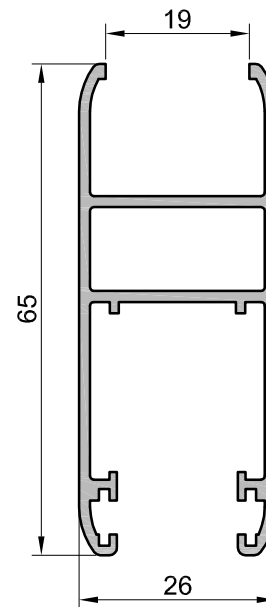

AZ 6007

769 g/m

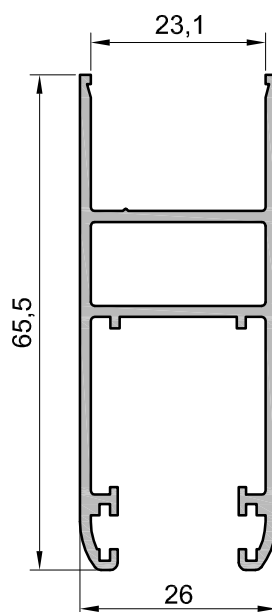

AZ 6003

811 g/m

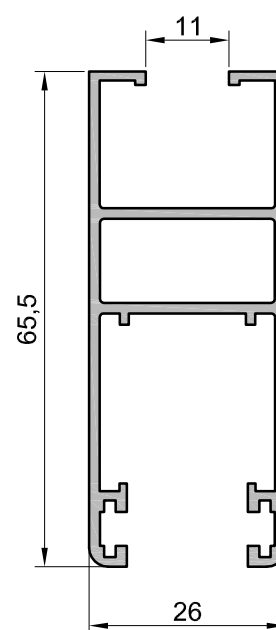

AZ 6010

982 g/ml

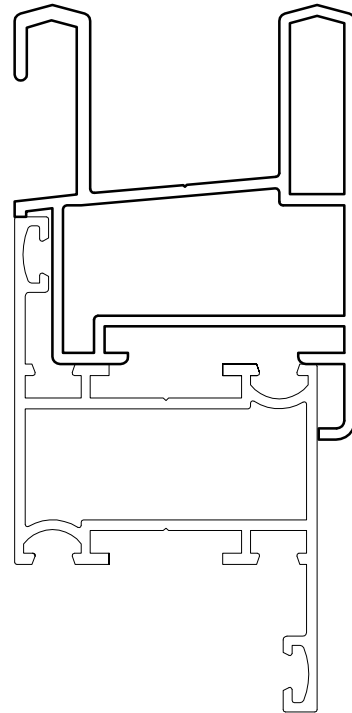
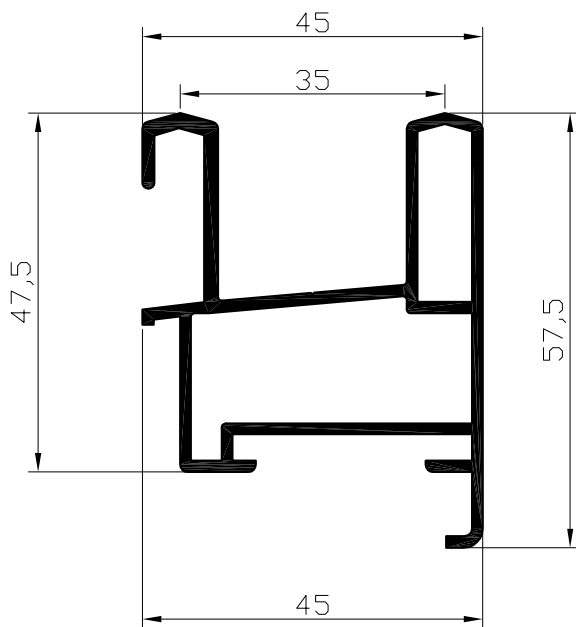

AZ 6011

335 g/ml

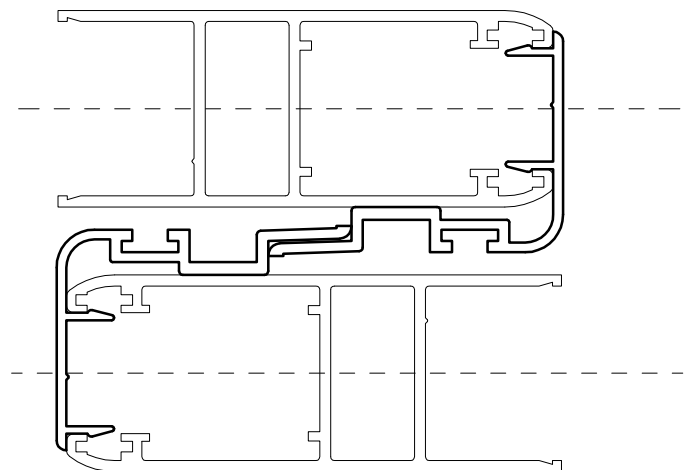
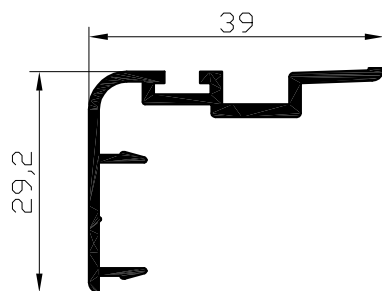

AZ 6016

859 g/ml

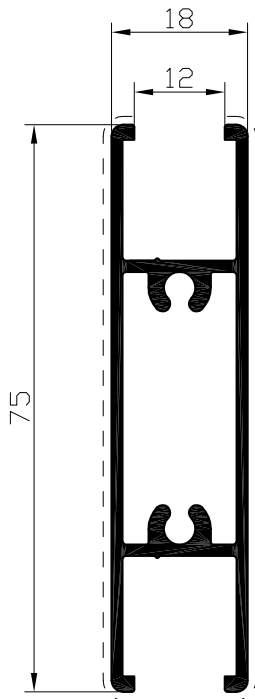

AZ 6012

899 g/ml

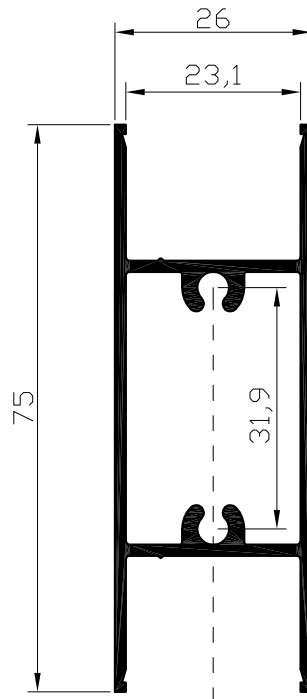

AZ 6015

177 g/ml

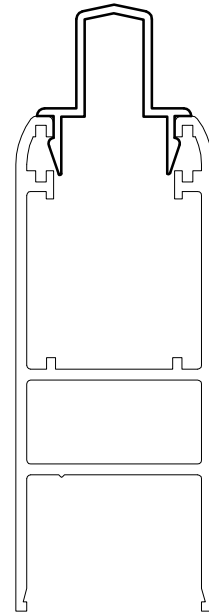
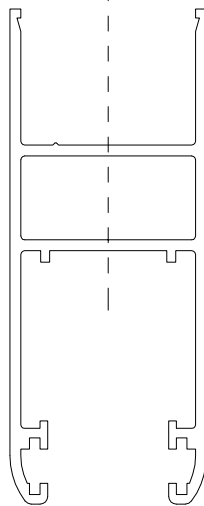
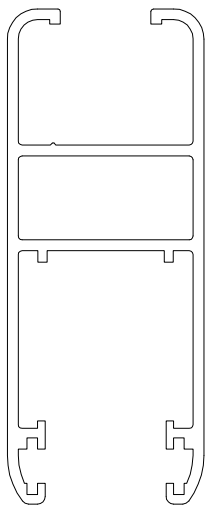
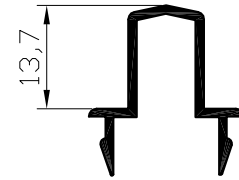

AZ 6013
199 g/ml

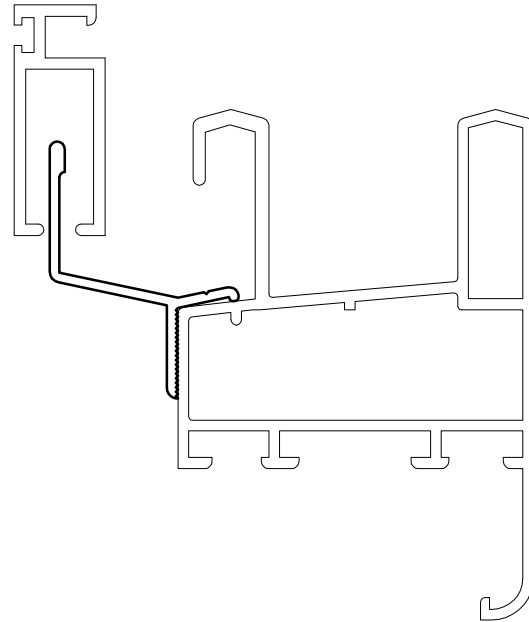
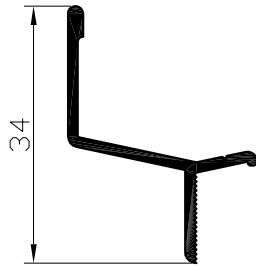

AZ 6014
205 g/ml

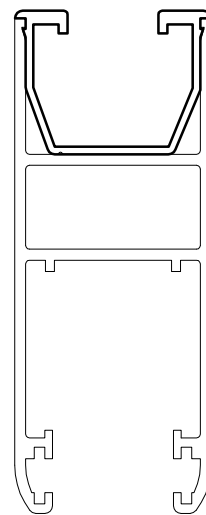
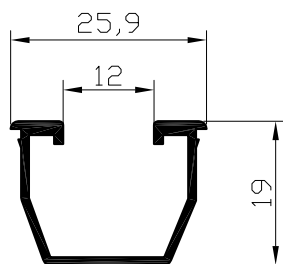

SCORREVOLE A 2 ANTE

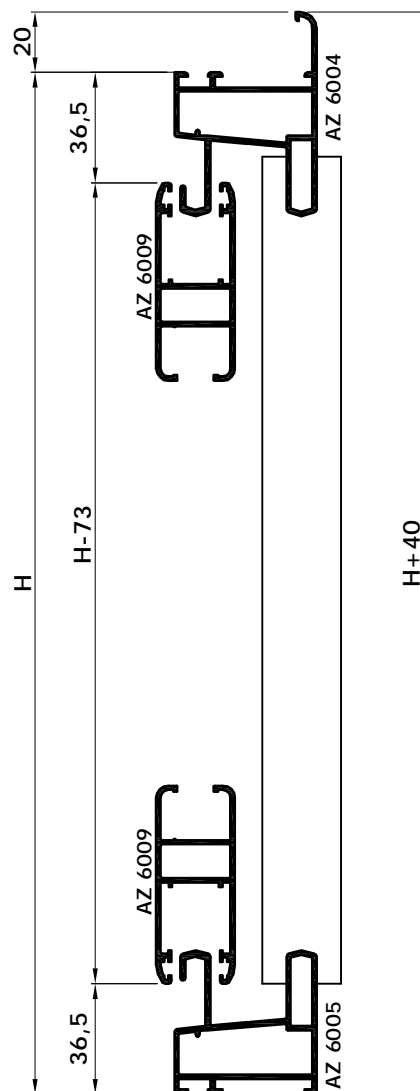
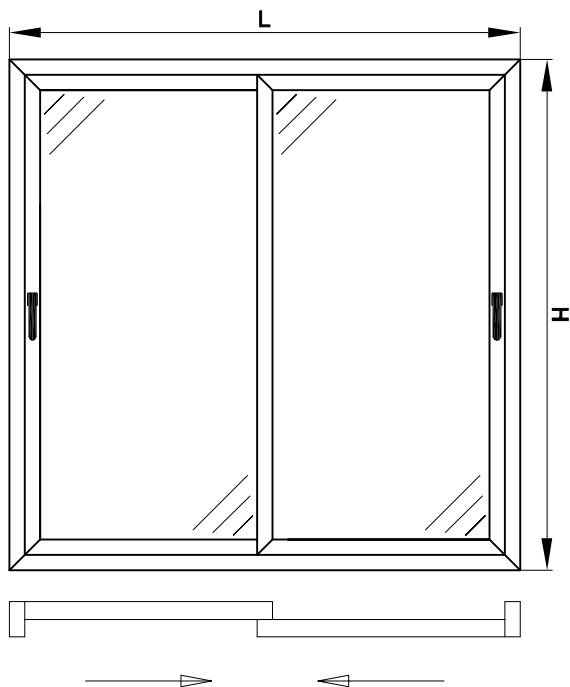

CALCOLO PESO PROFILI		TOTALE KG
Profili Orizz.	Kg/ml --- x L	
Profili Vert.	Kg/ml --- x H	
TOTALE		

DISTINTA TAGLIO VETRI			
Posizione	l	h	Q.tà
	-----	-----	2

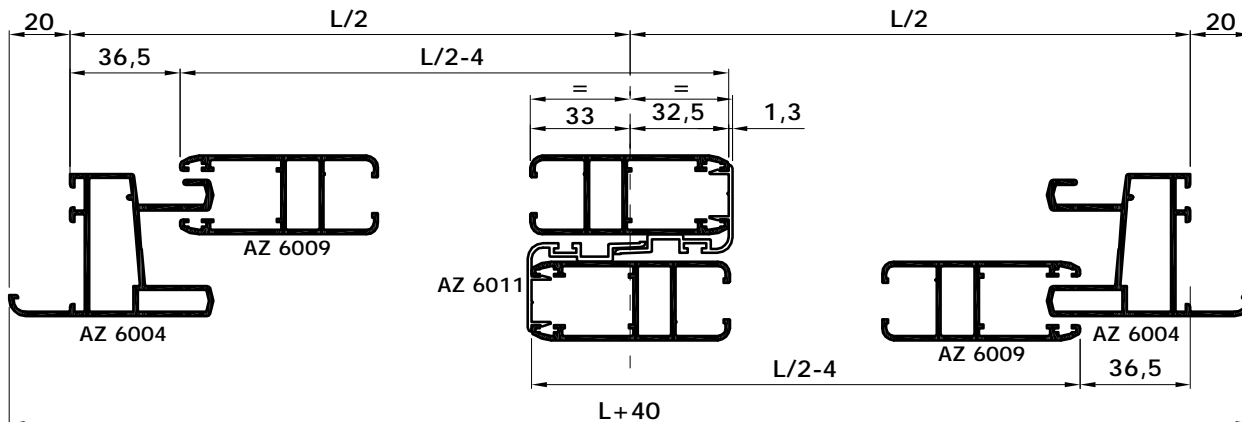

SCORREVOLE A 2 ANTE

DISTINTA TAGLIO PROFILI

Nr. Pezzi	CODICI	DESCRIZIONE	TAGLIO
2	AZ 6004	MONTANTE TELAIO	 H+40
1	AZ 6004	TRAVERSA SUP. TELAIO	 L+40
1	AZ 6005	TRAVERSA INF. TELAIO	 L
4	AZ 6009	MONTANTE ANTA	 H-73
4	AZ 6009	TRAVERSA ANTA	 L/2-4
2	AZ 6011	AGGANCIO CENTRALE	 H-73

ATLANTIS

DISTINTE DI TAGLIO

Cutting sizes



SCORREVOLE A 4 ANTE

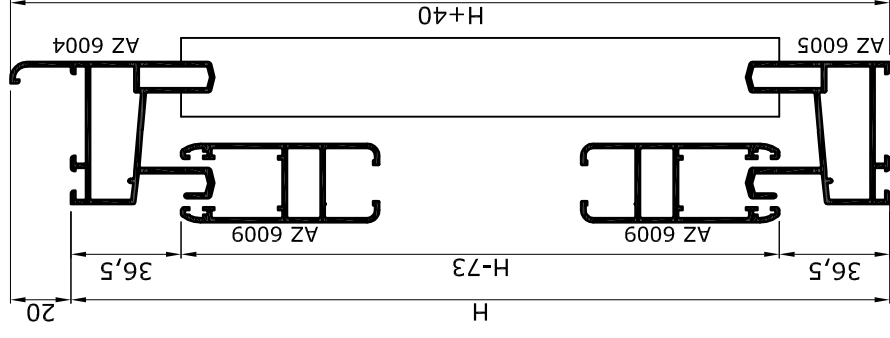
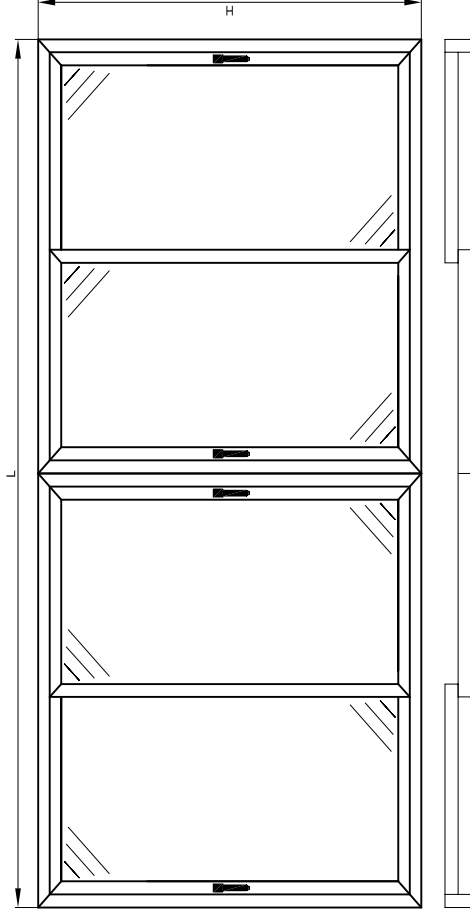

CALCOLO PESO PROFILI		TOTALE
		KG
Profili Orizz.	Kg/ml --- x L	
Profili Vert.	Kg/ml --- x H	
TOTALE		

DISTINTA TAGLIO VETRI

Posizione	l	h	Q.tà
	-----	-----	4

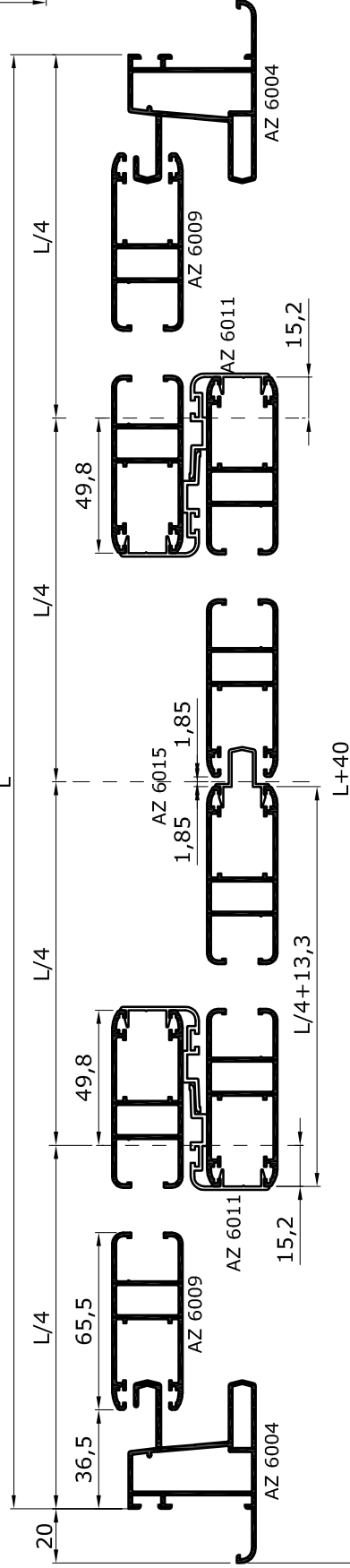

serie 60 scorrevole

SCORREVOLE A 4 ANTE

DISTINTA TAGLIO PROFILI

Nr. Pezzi	CODICI	DESCRIZIONE	TAGLIO
2	AZ 6004	MONTANTE TELAIO	 H+40
1	AZ 6004	TRAVERSA SUP. TELAIO	 L+40
1	AZ 6005	TRAVERSA INF. TELAIO	 L
8	AZ 6009	MONTANTE ANTA	 H-73
8	AZ 6009	TRAVERSA ANTA	 L/4+13,3
4	AZ 6011	AGGANCIO CENTRALE	 H-73
1	AZ 6015	AGGANCIO CENTRALE 4 ante	 H-73

Le dimensioni riportate sono espresse in mm